

Die Universalgrundplatten werden zur Adaption der unterschiedlichsten Skillair® FRL-Systeme verwendet. Bei Verwendung der Universalplatten in Verbindung mit den unterschiedlichen Adaptern, wird das System multifunktionell. Mehrere Baugrößen können miteinander montiert werden.

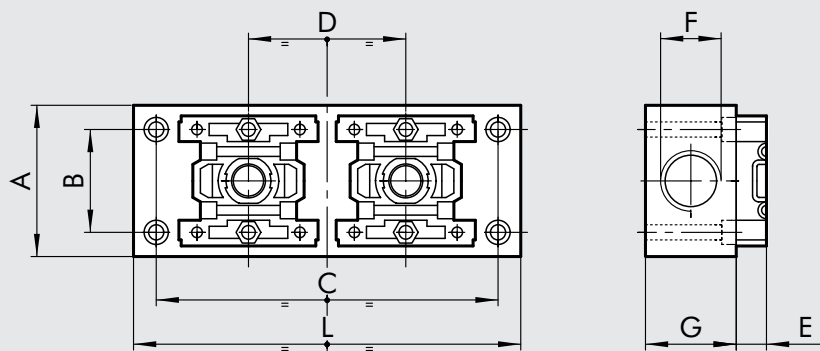

ABMESSUNGEN	100 - 2 POS.	100 - 3 POS	200 - 2 POS	200 - 3 POS	300 - 2 POS	300 - 3 POS
A	50	50	55	55	60	60
B	34	34	44	44	49	49
C	113	165	135	200	155	230
D	52	52	65	65	75	75
E	10	10	8.5	8.5	10.5	10.5
F	G 1/2	G 1/2	G 3/4	G 3/4	G 3/4	G 3/4
G	30	30	40	40	40	40
L	128	180	150	215	170	245

2-POSITIONEN



3-POSITIONEN

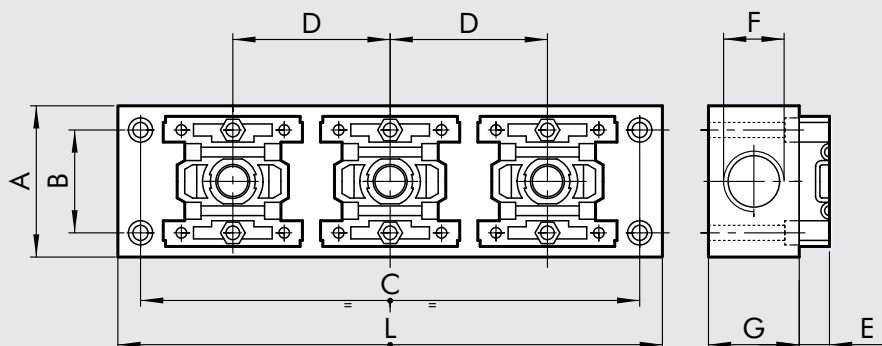

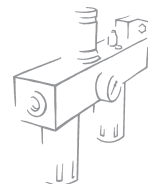

ABMESSUNGEN ADAPTER		BA 100	BA 200	BA 300
	A	46	59	69
	B	34	44	49
	C	34	44	49
	D	43	55	65
	E	10	8.5	10.5
	F	10	15	18
	G	M4 geeignet	M4 geeignet	M5 geeignet
	H	Es. 7	Es. 7	Es. 8
	I	5	2	5

ABMESSUNGEN GRÖSSENADAPTER		BA 100 - 200	BA 100 - 300	BA 200 - 300
	A	38.5	40.5	39

BESTELLNUMMERN	
Bestellnummer	Beschreibung
UNIVERSALPLATTEN	
9200202	ACC. SB 2 100
9300202	ACC. SB 2 200
9400202	ACC. SB 2 300
9200302	ACC. SB 3 100
9300302	ACC. SB 3 200
9400302	ACC. SB 3 300
ADAPTER	
9201801	BA 100
9321801	BA 200
9401801	BA 300
GRÖSSENADAPTER	
9301801	BA 100 - 200
9301802	BA 100 - 300
9301803	BA 200 - 300

ANMERKUNGEN	